

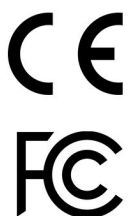

## RETRACTABLE TELESCOPIC BLADES SPEED GATE

### VX-SPEED-RB-XS-590-01

Retractable telescopic blades speed gate with brushless motor, dual leaf, single or dual sided, bi-directional, 304 stainless steel cover and body, with anti-tail gating, anti-reverse passing, anti-clamping, and illegal entry alarm.



# Specifications

## OPERATIONAL

|                             |                                 |
|-----------------------------|---------------------------------|
| Passage width               | 550mm ~ 900mm (Adjustable)      |
| Opening Speed               | Adjustable                      |
| Fastest Opening Speed       | 0.5 seconds                     |
| Passing Capacity            | 30 ~ 40 people / minute         |
| Mean Cycles Between Failure | 5 million cycles                |
| Motor                       | DC driven brushless motor       |
| Positioning                 | Motor driven                    |
| Operation                   | Unidirectional or bidirectional |
| Certification               | CE and FCC                      |

## STRUCTURE

|                       |  |
|-----------------------|--|
| Material              | 304 brushed stainless steel  |
| Body Thickness        | 1.5mm  |
| Cover Thickness       | 2.0mm  |
| Blade Material        | High impact polycarbonate  |
| Blade Thickness       | 12mm, 900mm wings are double layered   |
| Blade                 | Telescopic retraction  |
| Dimensions            | 1600 x 280 x 980 mm (L x W x H) for Machine of 2 x Single Sided, Single Leaf Gates, without Wing |
| IP Rating             | IP42 suitable for indoor applications only   |
| Operating Temperature | -20 °C to +70 °C   |

## INTERFACE

|               |                                 |
|---------------|---------------------------------|
| Communication | RS485                           |
| Input         | Dry contact                     |
| Reader        | Built-in or External (Optional) |

## SAFETY

|                      |   |
|----------------------|---|
| Sensors              | 6 Infrared sensors  |
| Anti-clamping        | Triple safety using sensors, mechanical and current detection |
| Anti-tailgating      | Yes   |
| Anti-reverse passing | Yes   |
| Illegal entry alarm  | Audible and visual alarm                                      |

## ELECTRICAL

|                   |  |
|-------------------|--|
| Operating voltage | 110VAC ~ 220VAC ±10% (50Hz ~ 60Hz)             |
| Operating power   | 30 Watt for single leaf, 60 Watt for dual leaf |

# Dimensions

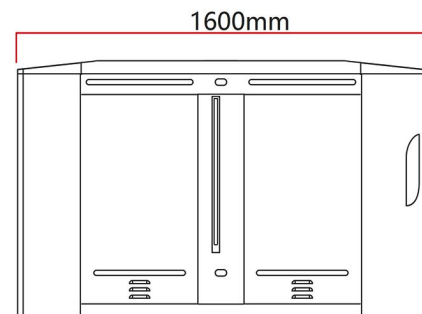
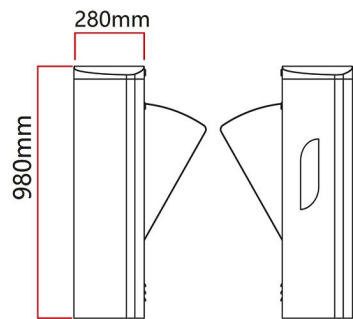

# Ordering Information

VX-SPEED-RB-SS-590-01  
 VX-SPEED-RB-SS-590-01  
 VX-SPEED-INRD-UPG  
 VX-SPEED-EXRD-UPG

Dual x Single Sided Retractable Blade Speed Gate with 550 to 900mm Passage Width  
 Single x Dual Sided Retractable Blade Speed Gate with 550 to 900mm Passage Width  
 In-Built Reader Provision with Card Reader Upgrade for a Single Direction \*  
 External Reader Provision with Card Reader Upgrade for a Single Direction \*

\* Reader Type to be confirmed with order, in case of bi-directional readers, 2 x UPG items to be ordered with speed gate.

Adkinns | 5063 Commercial Circle,  
 HQ | Concord, CA 94520  
 United States  
 Email | info@vertexparking.com  
 Website | www.vertexparking.com

Adkinns warrants all its products against any and all manufacturing defects from the date of product delivery from the factory and/or distribution center. Vertex's products have a warranty of 3 years.

VX-SPEED-RB-XS-590-01 – Datasheet V.001



©2022 Adkinns all rights reserved. Adkinns reserves the right to change the design and specifications without notice. Vertex is an entry, exit and parking management brand that is fully owned by Adkinns Inc.