



COMPACT TRIPOD TURNSTILE

VX-TURN-XS-550-01

Compact Tripod Turnstile with Brush Motor, Single Sided, Bi-directional, 304 Stainless Steel Cover and Body, Dry contact for input signal, Outdoor Rated, with anti-tail gating, anti-reverse passing, anti-clamping, and illegal entry alarm



Specifications

OPERATIONAL

Passage width	550mm
Passing Capacity	20 people / minute
Mean Cycles Between Failure	3 million cycles
Motor	Brush motor
Operation	Unidirectional or bidirectional
Certification	CE and FCC

STRUCTURE

Material	304 brushed stainless steel
Body Thickness	1.0mm
Cover Thickness	1.0mm
Arm Material	304 brushed stainless steel
Arm Thickness	1.0mm
Dimensions	420 x 330 x 980 mm (L x W x H)
IP Rating	IP54 suitable for indoor / outdoor applications

INTERFACE

Communication Input	RS485 Dry contact
---------------------	----------------------

SAFETY

Sensors	Yes
Anti-clamping	Yes
Anti-tailgating	Yes
Anti-reverse passing	Yes
Illegal entry alarm	Visual alarm

ELECTRICAL

Operating voltage	110VAC ~ 220VAC ±10% (50Hz ~ 60Hz)
Operating power	30 Watt

Dimensions

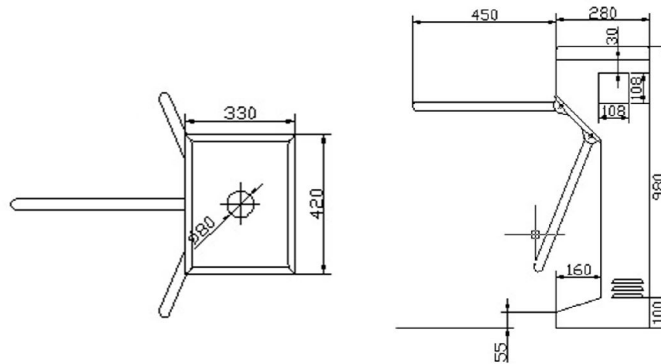

Ordering Information

VX-TURN-XS-550-01

Compact Tripod Turnstile with 550mm Passage Width

Adkinns | 5063 Commercial Circle,
HQ | Concord, CA 94520
United States
Email | info@vertexparking.com
Website | www.vertexparking.com

Adkinns warrants all its products against any and all manufacturing defects from the date of product delivery from the factory and/or distribution center. Vertex's products have a warranty of 3 years.

VX-TURN-XS-550-01 – Datasheet V.001



©2022 Adkinns all rights reserved. Adkinns reserves the right to change the design and specifications without notice. Vertex is an entry, exit and parking management brand that is fully owned by Adkinns Inc.